

(19) **DANMARK**

(10)

**DK 180342 B1**



(12)

## PATENTSKRIFT

Patent- og  
Varemærkestyrelsen

---

- (51) Int.Cl.: **E01H 1/08 (2006.01)**
- (21) Ansøgningsnummer: **PA 2019 01020**
- (22) Indleveringsdato: **2019-08-30**
- (24) Løbedag: **2019-08-30**
- (41) Alm. tilgængelig: **2021-01-08**
- (45) Patentets meddelelse bkg. og publiceret den: **2021-01-08**
- (73) Patenthaver:  
**TOFT v/Eddy Toft, Vindingvej 3, Ådum, 6880 Tarm, Danmark**
- (72) Opfinder:  
**Eddy Toft, Vindingvej 3, Ådum, 6880 Tarm, Danmark**
- (74) Fuldmægtig:  
**InnovatorLAB v/Marcus Reinholdt Pedersen, Viborggade 74, 2. th., 2100 København Ø, Danmark**
- (54) Titel: **VACUUM SUCTION APPARATUS FOR DIGGING MACHINE**
- (56) Fremdragne publikationer:  
**US 2006/0059652 A1**  
**JP S62235126 A**  
**KR 100979057 B1**  
**EP 0861043 A1**
- (57) Sammendrag:  
**A vacuum suction apparatus (100) configured to collect lightweight materials, includes a generally cuboidal frame (101), a suction unit (102), and a container (106). The suction unit (102) is positioned within the cuboidal frame (101) and comprises a suction port (103), an impeller (109), and a discharge port (105). The suction port (103) is positioned at a bottom end (102a) of the suction unit (102), and the impeller (109) is positioned within a casing (104) positioned above the suction port (103). The impeller (109) is in fluid communication with the suction port (103), where the impeller (109) rotates to generate a vacuum to suction the lightweight materials through the suction port (103). The impeller (109) further shreds the light materials during the suctioning of the lightweight materials. The discharge port (105) is circumferentially positioned along the casing (104) of the impeller (109) and is configured to discharge the suctioned light weight material into a container (106).**

Fortsættes...

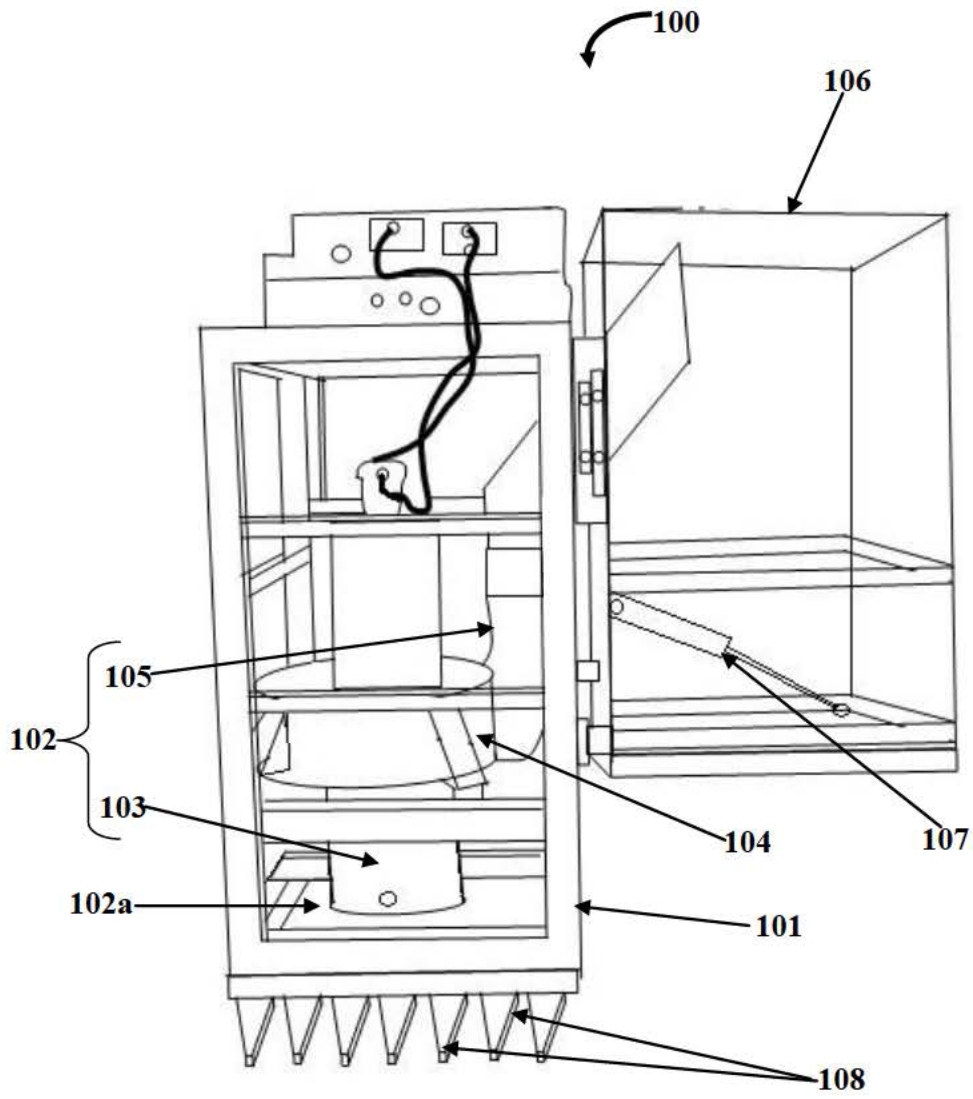

FIG. 1

## VACUUM SUCTION APPARATUS FOR DIGGING MACHINE

## BACKGROUND

5 [0001] Digging machines are widely used around the world for digging or excavation activities. These activities are performed especially in places where construction work is going on. The construction and related activities at a worksite can create bulk of waste material. Many systems were used in the past to collect and remove waste matter, for example, lightweight material comprising styrofoam, cardboard, plastic, etc, from  
10 industrial sites. The first methods involved manual disposal using the digging machine itself where the waste material was carried using the digging machine and disposed into a truck, where the truck carries the waste and disposes it in a waste disposal site where the waste is either recycled or incinerated. Conveyor belts were also used to carry the waste from the site to a waste collection truck. Another method involved disposing the waste at  
15 the site itself by incineration or digging compost pits. Advanced methods involved the use of blowers to create vacuum to suction the waste material to transfer the waste material to a disposal truck.

[0002] Prior art systems include, for example, US patent number 3651621 discloses a  
20 portable machine used to raise dirt, rocks, and the like from holes, such as fence post and utility pole holes and similar purposes, where components are provided in a closed chamber to extract the heavy and the light dirt particles by gravity separation and then to extract the fine particles by cloth bag filtration. Further, a blower draws a vacuum through a chamber and then through a hose which is lowered into the hole being cleaned.  
25 Another example is, for example, US patent number 5142732 which discloses an attachment for an industrial vacuum machine, where the attachment separates bulky items from finer materials passing through the hose. Here, the materials enter a separator chamber through a hose discharging into one side and exit through a second hose leading to the vacuum machine. In most of these cited prior arts, the lighter materials are  
30 separated by additional machinery which is time consuming and energy consuming.

There is no method available which can absorb as well as reduce the size of the light weight material in one-shot which will considerably reduce time and costs.

**[0003]** Another prior art, US 2006/0059652 of *Vry Alan*, discloses a debris collector is provided with an impeller mounted forward of the drive vehicle. The impeller is coupled to a movable snout which may be utilized to collect debris from the path of the vehicle, as well as areas lateral to the vehicle and debris which may be attached of a vertical structure. Still, another prior art, JP S62235126 A of *Morita Tokushu Kiko*, discloses suction of a solid and a congelation ever so easy, by connecting the attachment installed in an arm of a backhoe, supporting a suction tube to be extended out of a suction source at the vacuum side, to an opening at the suction side of the suction tube. However, above-mentioned prior arts fail to provide an alternative vacuum suction apparatus with cuboidal frame and the position of components within the frame. Further, above-mentioned prior arts also fail to describe an alternative vacuum suction apparatus with coulter members, which could be positioned proximal to the suction port.

**[0004]** Hence, there is a long felt but unresolved need for a vacuum suction apparatus for collecting lightweight materials, where the lightweight materials are suctioned using vacuum and reduced to smaller size within the same equipment.

20

#### SUMMARY OF THE INVENTION

**[0005]** The vacuum suction apparatus disclosed herein addresses the above stated need for collecting lightweight materials, and where the lightweight materials are suctioned using vacuum and reduced to smaller size within the same equipment. The vacuum suction apparatus disclosed herein which is configured to collect lightweight materials, comprises a generally cuboidal frame, a suction unit, and a container. The suction unit is positioned within the cuboidal frame and comprises a suction port, an impeller, and a discharge port. The suction port is positioned at a bottom end of the suction unit, and the impeller positioned within a casing positioned above the suction port. The impeller is in

30

fluid communication with the suction port, where the impeller is configured to rotate and generate a vacuum to suction the lightweight materials through the suction port. The impeller is further configured to shred the light materials during the suctioning of the lightweight materials. The discharge port is circumferentially positioned along the casing of the impeller and is configured to discharge the suctioned light weight material into a container. The container is fixedly attached to the cuboidal frame and configured to receive lightweight material through the discharge port.

**[0006]** In an embodiment, the vacuum suction apparatus disclosed herein, further comprises an external crushing unit removably attached proximal to the suction port, where the external crushing unit is configured to split or crush a selected set of materials from amongst the lightweight materials. In an embodiment, the vacuum suction apparatus disclosed herein, further comprises a set of coultter members fixedly attached to the cuboidal frame and positioned proximal to the suction port, where the set of coultter members are configured to break and loosen the lightweight materials. In an embodiment, the vacuum suction apparatus disclosed herein, further comprises a quick disconnect member positioned at a bottom end of the suction port, where the quick disconnect member is configured to removably attach suction tubes with variable dimensions.

**[0007]** In an embodiment, the suction tube comprises an elongate flexible tube, a connector member, and a solid ring. The connector member is positioned at an upper end of the elongate flexible tube which is removably connected to the quick disconnect member positioned at a bottom end of the suction port, where the connector member is configured to enable a quick connection and disconnection between the suction tube and the suction port. The solid ring is positioned at the distal end of the elongate flexible tube, where the solid ring retains the shape of the suction port during suction of the lightweight materials. In an embodiment, the vacuum suction apparatus disclosed herein, further comprises a hydraulic motor positioned at an upper section of the cuboidal frame, where the hydraulic motor is connected to the shaft of the impeller to provide drive to the impeller.

## BRIEF DESCRIPTION OF THE DRAWINGS

5 [0008] FIG. 1 exemplarily illustrates a front elevation view of the vacuum suction apparatus.

[0009] FIG. 2 exemplarily illustrates a cutaway view of the vacuum suction apparatus, showing the suction unit.

## 10 DETAILED DESCRIPTION OF THE INVENTION

[0010] FIG. 1 exemplarily illustrates a front elevation view of the vacuum suction apparatus **100**. The vacuum suction apparatus **100** is used along with a grave digging machine which is used for digging and excavation. Digging and excavation is primarily  
15 done on waste dump yards, removing building construction/demolition debris, etc. During such digging and excavation processes a large quantity of waste, for example, light weight hard materials like styrofoam, cardboard, plastic piles up which needs to be removed from the site for recycling or for incineration. The vacuum suction apparatus  
20 **100** uses vacuum suction principle to effectively remove the lightweight materials from the work site. Additional attachments are provided to crush certain lightweight materials which are hard and which does not fit into the components of the vacuum suction apparatus **100**.

[0011] The vacuum suction apparatus **100** disclosed herein which is configured to  
25 collect such lightweight materials comprise a generally cuboidal frame **101**, a suction unit **102**, and a container **106**. The cuboidal frame **101** is made of, for example, wrought iron. The suction unit **102** is positioned proximal to the ground so that the suction unit **102** is closer to the ground level where the lightweight materials are dumped. The suction unit  
30 **102** is positioned within the cuboidal frame **101** and comprises a suction port **103**, an impeller **109**, and a discharge port **105**. The suction port **103** is positioned at a bottom end

**102a** of the suction unit **102**, and the impeller **109** positioned within a casing **104** positioned above the suction port **103**. The suction port **103** is, for example, about 400 millimeter (mm) in diameter. The impeller **109** is in fluid communication with the suction port **103**, where the impeller **109** is configured to rotate to generate a vacuum to suction  
5 the lightweight materials through the suction port **103**.

[0012] The impeller **109** is further configured to shred the light materials during the suctioning of the lightweight materials. The discharge port **105** is circumferentially positioned along the casing **104** of the impeller **109** and is configured to discharge the  
10 suctioned light weight material into a container **106**. The container **106** is fixedly attached to the cuboidal frame **101** and configured to receive lightweight material through the discharge port **105**. In an embodiment, the vacuum suction apparatus **100** further comprises a lid member **107** positioned within the container **106**, where the lid member **107** is hingedly connected proximal to the discharge port **105** and is configured to open  
15 and close the discharge port **105**. In an embodiment, the vacuum suction apparatus **100** disclosed herein, further comprises a set of coulter members **108** fixedly attached to the cuboidal frame **101** and positioned proximal to the suction port **103**, where the set of coulter members **108** are configured to break and loosen the lightweight materials.

[0013] FIG. 2 exemplarily illustrates a cutaway view of the vacuum suction apparatus **100**, showing the suction unit **102**. The impeller **109** mentioned in the description of FIG. 1 is positioned inside the casing **104** as shown in FIG. 2. The impeller **109** is, for example, about 500 millimeter (mm) in diameter. In an embodiment, the vacuum suction apparatus **100** disclosed herein, further comprises a quick disconnect member **110**  
25 positioned at a bottom end **103a** of the suction port **103**, where the quick disconnect member **110** is configured to removably attach suction tubes **111** with variable dimensions. In an embodiment, the suction tube **111**, for example, an elongate flexible hose, comprises an elongate flexible tube **112**, a connector member **113**, and a solid ring **114**. The connector member **113** is positioned at an upper end **112a** of the elongate  
30 flexible tube **112** which is removably connected to the quick disconnect member **110**

positioned at a bottom end **103a** of the suction port **103**, where the connector member **113** is configured to enable a quick connection and disconnection between the suction tube **111** and the suction port **103**.

5 **[0014]** The solid ring **114** is positioned at the distal end **112b** of the elongate flexible tube **112**, where the solid ring **114** retains the shape of the suction port **103** during suction of the lightweight materials. In an embodiment, the vacuum suction apparatus **100** disclosed herein, further comprises a hydraulic motor **115** positioned at an upper section **101a** of the cuboidal frame **101**, where the hydraulic motor **115** is connected to the shaft  
10 **116** of the impeller **109** to provide drive to the impeller **109**. In an embodiment, the vacuum suction apparatus **100** disclosed herein, further comprises an external crushing unit **117**, removably attached proximal to the suction port **103**, where the external crushing unit **117** is configured to split or crush a selected set of materials, for example, materials of larger dimensions, from amongst the lightweight materials.

15

**[0015]** The lightweight materials are collected are positioned or transferred proximal to the solid ring **114** is positioned at the distal end **112b** of the elongate flexible tube **112** via a digging machine or a belt conveyor. The hydraulic motor **115** is activated which drives the impeller **109** creating a vacuum suction force, and therefore the suction process of the  
20 lightweight materials is initiated. The lightweight material is first suctioned through the suction tube **111**, the suction port **103** and then into the casing **104** containing the impeller **109** as shown by the arrows in FIG. 2. Inside the casing **104**, the impeller **109** further shred the lightweight materials into finer particles and then the lightweight materials are transferred to the container **106** through the discharge port **105** as shown by  
25 the arrows in FIG. 2. In example, the external crushing unit **117** splits and crushes lightweight materials of larger dimensions, from amongst the lightweight materials transferred proximal to the suction tube **111**. The suction tube **111** is disconnected via the quick disconnect member **110**, so that the crushed lightweight material via the external crushing unit **117** is suctioned directly through the suction port **103**.

30



[0016] The foregoing examples have been provided merely for the purpose of explanation and are in no way to be construed as limiting of the present concept disclosed herein. While the concept has been described with reference to various embodiments, it is understood that the words, which have been used herein, are words of description and  
5 illustration, rather than words of limitation. Further, although the concept has been described herein with reference to particular means, materials, and embodiments, the concept is not intended to be limited to the particulars disclosed herein; rather, the concept extends to all functionally equivalent structures, methods and uses, such as are within the scope of the appended claims. Those skilled in the art, having the benefit of the  
10 teachings of this specification, may affect numerous modifications thereto and changes may be made without departing from the scope and spirit of the concept in its aspects.

## KRAV

1. Et vakuumsugeapparat (**100**) konfigureret til at indsamle lette materialer, omfattende:

en generelt kvaderformet ramme (**101**);

en sugeenhed (**102**) placeret inden i en kvaderformet ramme (**101**), sugeenheden (**102**) omfattende:

en sugeport (**103**) placeret i en nedre ende (**102a**) på sugeenheden (**102**);

blæserhjul (**109**) placeret i et hus (**104**) placeret over sugeporten (**103**), blæserhjulet (**109**) i væskekommunikation med sugeporten (**103**), hvor blæserhjulet (**109**) er konfigureret til at rotere for at generere et vakuum til sugning af de lette materialer gennem sugeåbningen (**103**), hvor blæserhjulet (**109**) er yderligere konfigureret til at makulere de lette materialer under sugningen af de lette materialer;

et sæt skærende dele (**108**) fastgjort til den kvaderformede ramme (**101**) og placeret proksimalt til sugeåbningen (**103**), hvor sættet med skærende dele (**108**) er konfigureret til at bryde og løsne de lette materialer;

et hurtigt frakoblingsmedlem (**110**) placeret i en nedre ende (**103a**) af sugeporten (**103**), hvor det hurtige frakoblingselement (**110**) er konfigureret til at kunne fjerne det aftagelige sugerør (**111**) med variable dimensioner og

en afgangsport (**105**) placeret i en periferisk sidevæg af blæser-hjulet (**109**), hvor afgangsporten (**105**) er konfigureret til at udlede sugets lette materiale i en beholder (**106**);

hvor beholderen **(106)** er fastgjort til den kvaderformede ramme **(101)** og konfigureret til at modtage letvægtsmateriale gennem afgangsporten **(105)**.

2. Vakuumsugeapparatet **(100)** ifølge krav 1, yderligere omfattende et sugerør **(111)**, hvor sugerøret **(111)** omfatter:

et aflangt fleksibelt rør **(112)**;

en forbindelsesdel **(113)** placeret i en øvre ende **(112a)** af det aflange fleksible rør **(112)** som er aftageligt forbundet til hurtigkoblingselementet **(110)** placeret i en nedre ende **(103a)** af sugeporten **(103)**, hvor forbindelselementet **(113)** er konfigureret til at muliggøre en hurtig tilkobling og frakobling mellem sugerøret **(111)** og sugeporten **(103)**; og

en fast ring **(114)** placeret i den distale ende **(112b)** af det aflange fleksible rør **(112)**, hvor den faste ring **(114)** bevarer formen på sugeporten **(103)** under sugning af de lette materialer.

3. Vakuumsugeapparatet **(100)** ifølge krav 1, yderligere omfattende en hydraulisk motor **(115)** placeret i en øvre sektion **(101a)** af den kvaderformede ramme **(101)**, hvor den hydrauliske motor **(115)** er forbundet med akslen **(116)** på blæserhjulet **(109)** for at driveblæserhjulet **(109)**.

4. Vakuumsugeapparatet **(100)** ifølge krav 1, yderligere omfattende et lågelement **(107)** placeret i beholderen **(106)**, hvor lågelementet **(107)** er hængslet nær til afgangsporten **(105)** og er konfigureret til at åbne og lukke afgangsporten **(105)**.

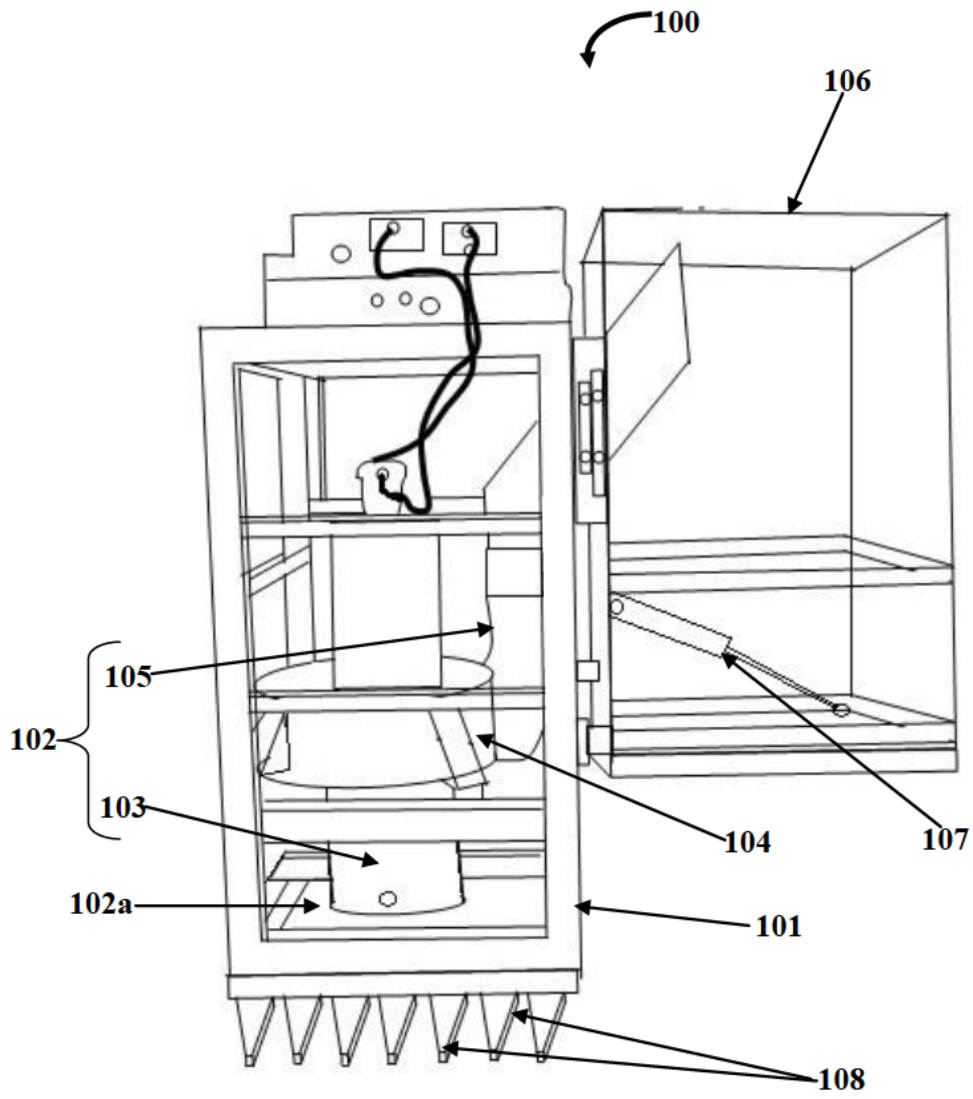

FIG. 1

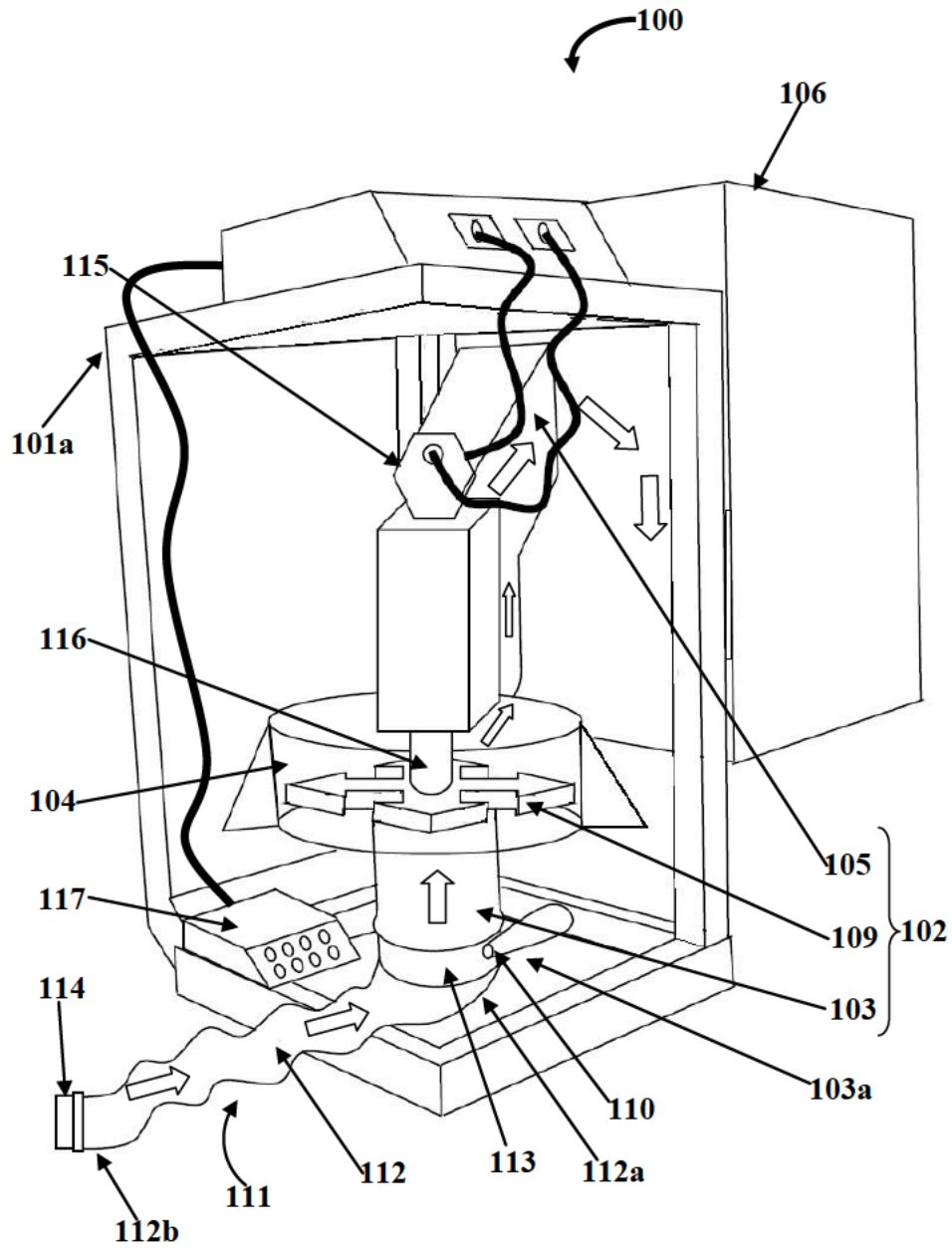

FIG. 2